

CW Series 76

36 mm bore – Triplex Plunger Pumps

FEATURES

- The industry's choice for high-flow applications
- Forged brass manifold with an exclusive lifetime warranty
- Large-capacity, die-cast, anodized aluminum oil-bath crankcase
- Over-sized connecting rods for maximum life
- Heavy-duty tapered roller bearing.
- Solid ceramic plungers with continuously lubricated packings
- Unitized stainless steel inlet and discharge valves

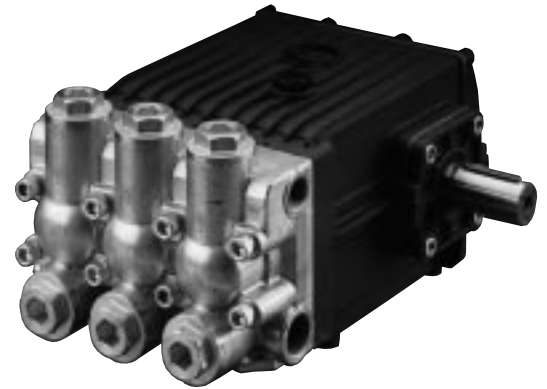

SPECIFICATIONS

Pump Model	CW61	CW81
Maximum Volume	17.0 GPM	21.0 GPM
Maximum Discharge Pressure	1200 PSI	
Maximum Pump Speed	1000 RPM	
Maximum Inlet Vacuum	9 ft. water (7.9 in. Hg)	
Bore	1.417 in. / 36 mm	
Stroke (in./mm)	.945 / 24	1.102 / 28
Crankcase Oil Capacity	91 oz.	
Maximum Fluid Temperature	165°F	
Inlet Port Thread	1-11 BSPP-F	
Discharge Port Thread	3/4-14 BSPP-F	
Shaft Diameter.	1.378 in. / 35 mm	
Weight	92 lbs.	
Dimensions	15.6 x 14.0 x 9.5 in.	

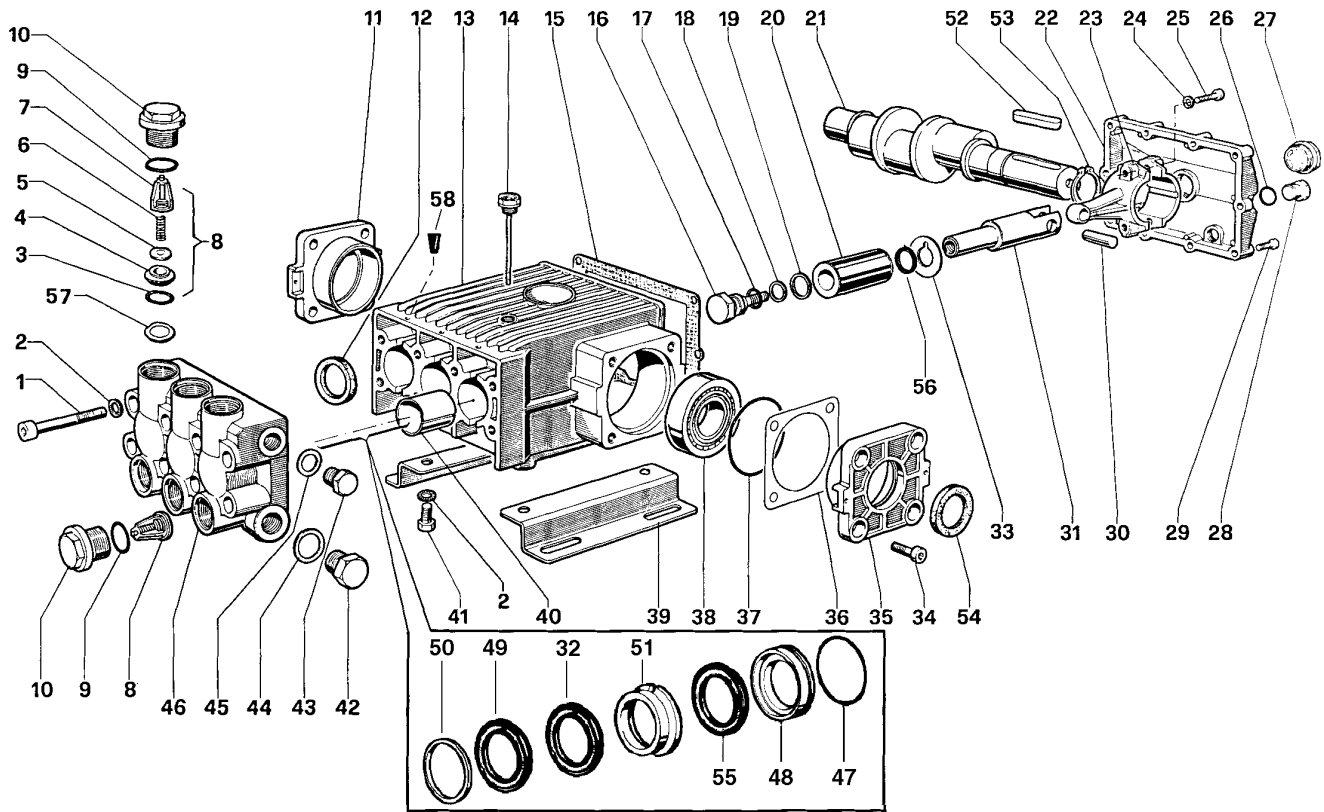

PARTS LIST

ITEM	PART NO.	DESCRIPTION	KIT NO.	QTY.	ITEM	PART NO.	DESCRIPTION	KIT NO.	QTY.	ITEM	PART NO.	DESCRIPTION	KIT NO.	QTY.
1.	99.4418.00	Screw		8	20.	69.0400.09	Plunger (36 mm)		3	39.	76.2000.74	Pump Feet		2
2.	96.7195.00	Washer		12	21.	76.0211.35	Crankshaft (CW61)		1	40.	90.9174.00	Bushing		3
3.	90.4059.00	O-Ring	943	6		76.0210.35	Crankshaft (CW81)		1	41.	99.4266.00	Screw		4
4.	36.2011.66	Valve Seat	943	6	22.	76.1600.22	Cover		1	42.	98.2325.00	Cap		1
5.	36.2010.76	Valve Plate	943	6	23.	76.0303.01	Connecting Rod		3	43.	98.2265.00	Cap		1
6.	94.7450.00	Spring	943	6	24.	96.7104.00	Washer		6	44.	96.7870.00	Washer		1
7.	36.2009.51	Valve Guide	943	6	25.	99.3720.00	Screw		6	45.	96.7700.00	Washer		1
8.	36.7065.01	Valve Assembly	943	6	26.	90.3833.00	O-Ring		2	46.	76.1251.41	Manifold		1
9.	90.4065.00	O-Ring		6	27.	97.5968.00	Oil Indicator		1	47.	90.3903.00	O-Ring	939,940	3
10.	98.2420.00	Cap		6	28.	98.2100.00	Cap		2	48.	76.0801.70	Packing Retainer	939,940	3
11.	76.1501.22	Cover		1	29.	99.1897.00	Screw		10	49.	90.2820.00	Packing	939	3
12.	90.1670.00	Oil Seal	44	3	30.	97.7400.00	Wrist Pin		3	50.	69.1002.93	Head Ring	41,939	3
13.	76.0100.22	Crankcase		1	31.	77.0500.54	Plunger Guide		3	51.	69.2170.70	Intermed. Ring	939	3
14.	98.2271.00	Dip Stick		1	32.	90.2818.00	Restop Ring	939	3	52.	91.4978.00	Key		1
15.	76.2119.84	Cover Gasket		1	33.	96.7568.00	Washer		3	53.	90.0695.00	Snap Ring		1
16.	69.2195.66	Plunger Screw	74	3	34.	99.3652.00	Screw		8	54.	90.1672.00	Oil Seal	32	1
17.	90.3841.00	O-Ring	74	3	35.	76.1500.22	Cover		1	55.	90.2823.00	Seal, Low Pressure	939	3
18.	90.5107.00	Anti-Ext. Ring	74	3	36.	76.2200.78	Shim		2	56.	76.2114.70	Spacer, Plunger		3
19.	96.7555.00	Washer	74	3	37.	90.4141.00	O-Ring		2	57.	96.7570.00	Back-up Ring Valve Seat	943	6
					38.	91.8474.00	Bearing		2	58.	600600	Plug, Tapered		3

REPAIR KITS

KIT NO.	32	41	44	74	939	940	943
ITEM NO.s INCLUDED IN KIT	54	50	12	16, 17, 18, 19	32, 47, 48, 49, 50, 51, 55, 32	47, 48	3, 4, 5, 6, 7, 57 (8)
NUMBER OF ASSEMBLIES IN KIT	2	6	3	3	1	3	6
NUMBER OF CYLINDERS KIT WILL SERVICE	-	3	3	3	1	3	3

TORQUE SPECS*

Position	Ft.-lbs.
1	51.5
10	95.8
16	29.4
25	29.4
27	13.2
28	29.4
29	7.3
34	29.4
41	51.5
42	73.7
43	51.5